

URSA

AURATON S14

Multi-function pump controller

Multi-function controller works with central heating circulation pumps (CH) and domestic hot water pumps (DHW). It also works with a thermo-fireplace (fireplace with a water jacket) and solid fuel supply boilers. The user can set the temperature between 10°C and 85°C. The temperature measurement is carried out between 0°C and 99°C. Depending on the set temperature, the controller switches the pump on or off. AURATON Ursa has been equipped with several useful options, including the function of limiting the fan power (automatically or manually) and adding fuel to the furnace while blocking fan operation. The controller ensures safe operation of the pump. If the temperature in the installation rises above 85°C, the emergency heat extraction function is activated. In this case, a domestic hot water tank with the support of a central heating pump will be used as a heat buffer. AURATON Ursa is equipped with an LCD display with current work readings. Also, the screen is divided into 4 parts, each of which handles a separate device. The controller has an AntiStop function, which prevents the impeller of an unused pump from seizing up.



LCD LCD display with current work readings

HI Hysteresis between 2°C - 10°C

Fuel adding function

Operates in the central heating and domestic hot water system

In central heating system it works with a thermo-fireplace and solid fuel supply boilers

Emergency heat extraction function

TECHNICAL DATA

Power supply	230V AC, 50Hz, 3W
Operating temperature range	0 – 40°C
Working status signalling	LCD display
Temperature control range	10 – 85°C
Temperature measuring range	0 – 99°C
Hysteresis	2 – 10°C
Maximum load for output sum	Max. 250V AC, max. 6A
Blow-through time and interval between blow-throughs	0 ÷ 59 seconds and 1 ÷ 99 min
Ingress protection	IP 20

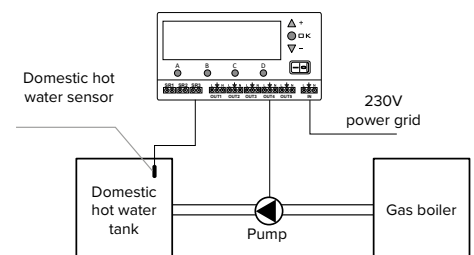
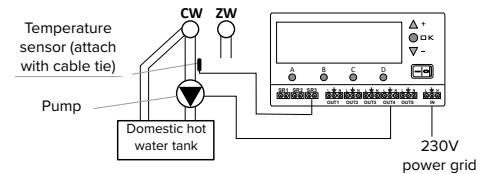
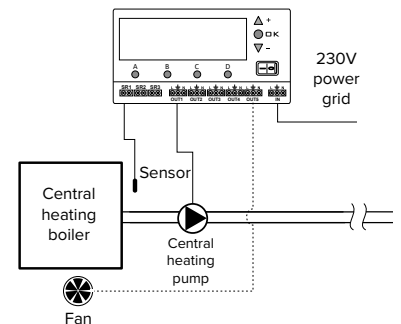
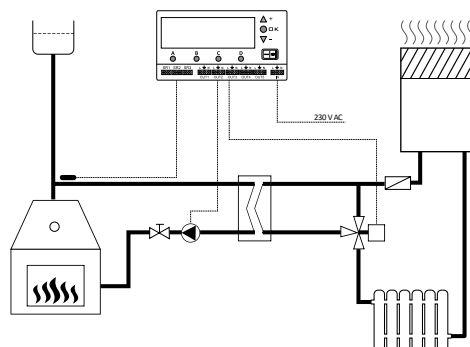
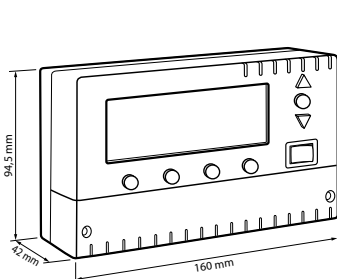

FOR SMARTER LIVING



Manufacturer:
LARS, Swierkowa 14 Str., 64-320 Niepruszewo, Poland
tel. +48 61 840 40 40, e-mail: trade@auraton.pl
www.auraton.pl/en www.auratonsmart.com

